

Features

- NFPA 70, NFPA 496, ISA 12.4 standards
- Optional alarm output indicates air lock failure
- Type Y system certified for Class I, Division 1 to Division 2
- Type Z system certified for Class I, Division 2 to nonhazardous
- Enclosure volume up to 15 ft³

Function

Model 1002 is a Rapid Exchange[®] purging system that operates on a supply of compressed instrument air or inert gas. It regulates and monitors pressure within sealed (protected) enclosure(s), in order to remove and prevent flammable gas or vapor accumulations. The system accomplishes four air exchanges and maintains a "safe" (0.25") pressure. A Pepperl+Fuchs Model EPV-2 Enclosure Protection Vent is required for proper operation. This process reduces the hazardous (classified) area rating within the enclosure(s), in accordance with the NEC - NFPA 70, Article 500, NFPA 496 and ISA 12.4.

Assembly

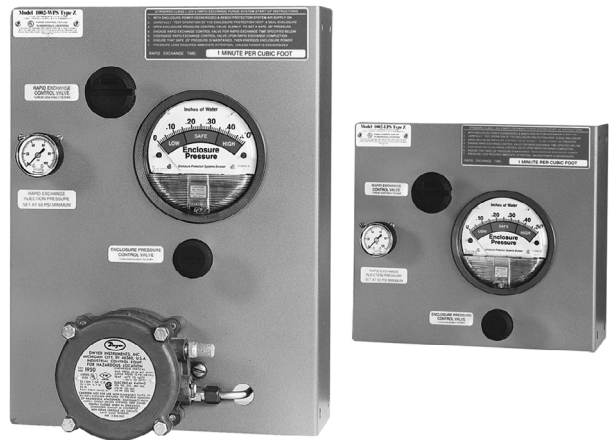

BEBCO EPS[®]

Connection

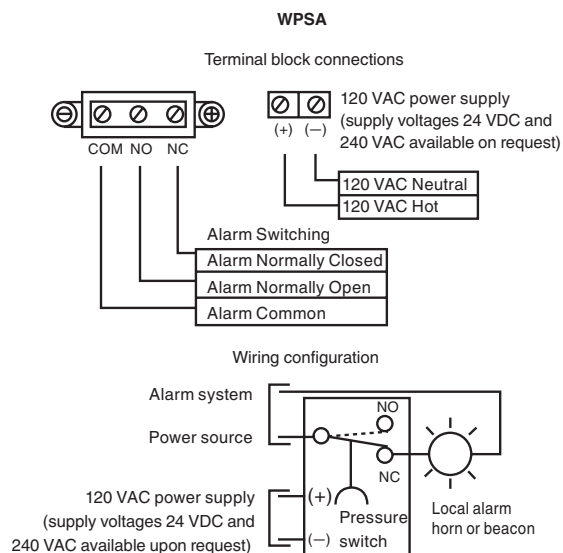
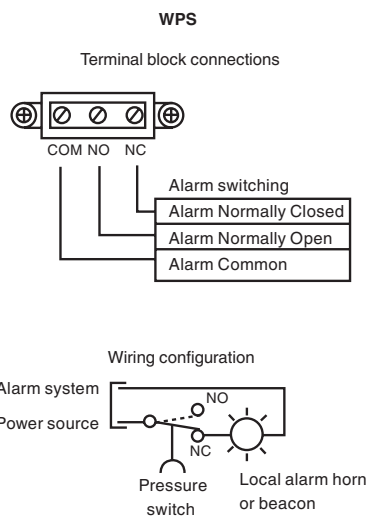

Release date 2013-09-26 23:17 Date of issue 2013-09-26 t156402_eng.xml

General specifications	
Series	1002
Hazardous environment	gas
Electrical specifications	
Connection	Terminal blocks
Output	
Output I	-WPS-
Output type	Switch contacts
Contact loading	120 VAC @ 15 A
Output II	-WPSA-
Output type	Switch contacts
Contact loading	120/220 VAC; 24 VDC @ 10 A; 125 VDC @ 50 mA power requirements: 24 / 120 / 240 VDC @ 3 / 4 / 11 watts
Pneumatic parameters	
Protective gas supply	Instrument grade air or inert gas
Pressure requirement	80 - 120 psi
Safe pressure	Setpoint: 0.25" (6.35 mm) Flow rate: 0.1 - 3.5 SCFH (2.8 - 99 l/hr)
Operating conditions	
Process conditions	
Capacity and filtration	1.5 oz @ 20 µ
Exchange pressure	3" - 5"
Exchange flow rate	4 SCFM / 240 SCFH (With regulator set to 60 psi min. during exchange)
Exchange time	1 min / ft ³
Ambient conditions	
Ambient temperature	-29 ... 49 °C (-20.2 ... 120.2 °F)
Mechanical specifications	
Connection type	System supply port: 1/2" FPT Enclosure supply port: 1/2" FPT Enclosure reference fitting: 1/4" tube Switch conduit port size: 1/2" FPT
Material	Filter regulator body: zinc w/enamel finish Regulator handle & bowl: polycarbonate Enclosure pressure gauge: alum. w/enamel finish Rapid Exchange@gauge: poly case and brass tube Tube fittings & valves: 316 ss forged body Tubing: 316 ss 1/4" .035 welded System nameplate: silk screened Lexan® & ss Fastener hardware: alum. & stainless steel Mounting plate: 316 14 ga #3 brush ss EXP pressure switch body: anodized cast aluminum Enclosure warning nameplate: silk screened ss
Mass	1002-LPS* 4.5 kg (10 lb) 1002-WPS* 6.8 kg (15 lb)
International approvals	
FM approval	Type Y LPS: Class I, Division 1, Groups A, B, C, D WPS: Class I, Division 1, Groups C, D WPSA: Class I, Division 1, Groups A, B, C, D Type Z LPS: Class I, Division 2, Groups A, B, C, D WPS: Class I, Division 2, Groups C, D WPSA: Class I, Division 2, Groups A, B, C, D
UL approval	
cULus	Type Y LPS: Class I, Division 1, Groups A, B, C, D WPS: Class I, Division 1, Groups C, D WPSA: Class I, Division 1, Groups A, B, C, D Type Z LPS: Class I, Division 2, Groups A, B, C, D WPS: Class I, Division 2, Groups C, D WPSA: Class I, Division 2, Groups A, B, C, D

Release date 2013-09-26 23:17 Date of issue 2013-09-26 t156402_eng.xml

Assembly

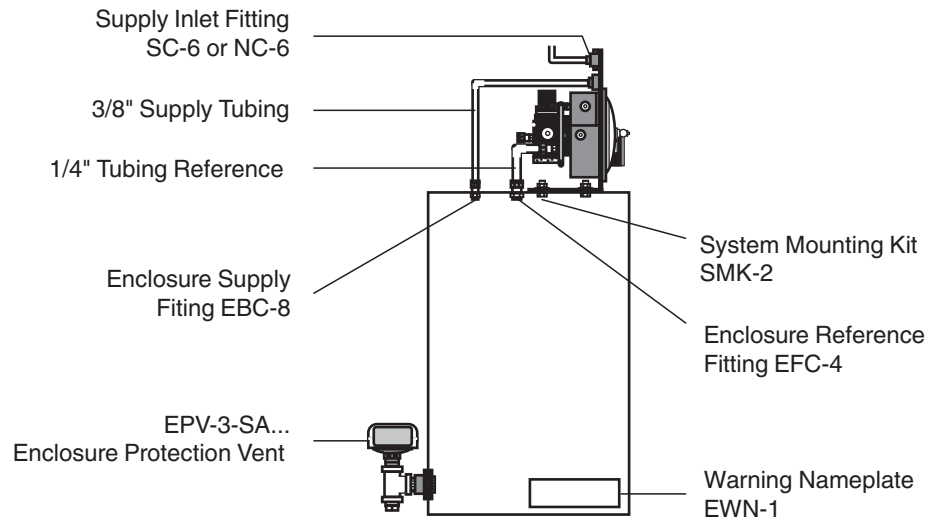

Dimensions

Overall system dimensions			
LPS / WPS	LH - left hand	RH - right hand	TM - top mount
Height	10 / 15	10 / 15	10 / 10
Width	11 / 11	11 / 11	11 / 16
Depth	6 / 7.5	6 / 7.5	6 / 7.5
LPS / WPS	BM - bottom mount	WM - wall mount	FM & PM - surface
Height	10 / 10	10 / 15	12 / 17
Width	11 / 16	11 / 11	13 / 13
Depth	6 / 7.5	7.75 / 9.25	5 / 6.5
<p>Dimensions in inches. Mounting dimensions available upon request. FM & PM panel cutout dimensions: LPS - 11 h x 12 w WPS - 16 h x 12 w.</p> <p>Height & Width dimensions reflect mounting plate measurements. Depth dimension reflects overall measurement of system, including components.</p>			

Release date 2013-09-26 23:17 Date of issue 2013-09-26 t156402_eng.xml

System Accessories	
Connection fittings	
Part	Description
NC-4	1/4" ninety connector
SC-4	1/4" straight connector
EFC-4	1/4" flush connector
EBC-4	1/4" bulkhead connector
EPC-12	3/4" pipe connector
Additional items	
Part	Description
SMK-2	Surface Mounting Kit (-LH-, -RH-, -TM-, -BM-, -WM- models)
SMK-8	Surface Mounting Kit (-FM-, -PM- models)
EPSK-1	Explosion Proof Switch Kit (Class I areas)
EPSK-1A	Explosion Proof Switch Kit (Class I areas)
GPSK-1	General-purpose Switch Kit (Class I areas)
RAH	Remote Alarm Horn
RAB-1	Div. 1 Remote Alarm Beacon
RAB-2	Div. 2 Remote Alarm Beacon
LCK	"L" style conduit fitting kit
TCK	"T" style conduit fitting kit
Warning nameplates	
Part	Description
EWN-1	Class I enclosure warning
ETW	Enclosure temperature warning
Installation & Operation Manual	
Part	Description
DOCT-1355	Installation and Operation Manual

Release date 2013-09-26 23:17 Date of issue 2013-09-26 t156402_eng.xml

Type code/model number

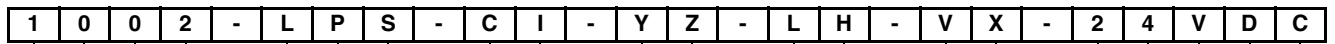

1002 series model number
LPS less pressure switch
WPS with pressure switch
WPSA with pressure switch (120 VAC standard)
CI Class I area
YZ Div 1 to Div 2; Div 2 to nonhazardous
Area classification
CI Class I area
System style
LPS less pressure switch
WPS with pressure switch
WPSA with pressure switch (120 VAC standard)
Mounting configuration
LH vertical mount left
RH vertical mount right
TM horizontal mount top
BM horizontal mount bottom
WM wall mount
FM frame mount
PM panel mount (LPS style only)
Cooler indicator gauge
VX vortex
24VDC 24 VDC
240VAC 240 VAC
120VAC 120 VAC

* only for WPSA option

Release date 2013-09-26 23:17 Date of issue 2013-09-26 t156402_eng.xml